

TRUSTED MINING OEM HEAVY DUTY A/C HOSE & FITTING



Air conditioning solutions for:

- Mining & Civil Heavy Equipment
- Diggers, Drills & Trucks
- Bus refrigeration
- Haul Trucks, Cars

Auto Tech mining in Western Australia offers maintenance and repair for all mining machines on-site and workshop by experienced technicians.

- SIGMA Air conditioning parts
- Liebherr, CAT & Terex yearly A/C Service Kit
- Supply OEM Liebherr Excavator A/C Hose Kit R9200, R9250, R9400, R996 etc
- Supply Drill A/C Hose Kit. PitViper, D65, Sandvik etc

P: 0412 228 671 or 08 6118 4152
E: info@autotechmining.com.au
www.autotechmining.com.au

AUSTRALIA'S ONLY
 AUTHORISED MANULI AIR
 CONDITIONING DEALER

REFRIGERATION & AIR CONDITIONING

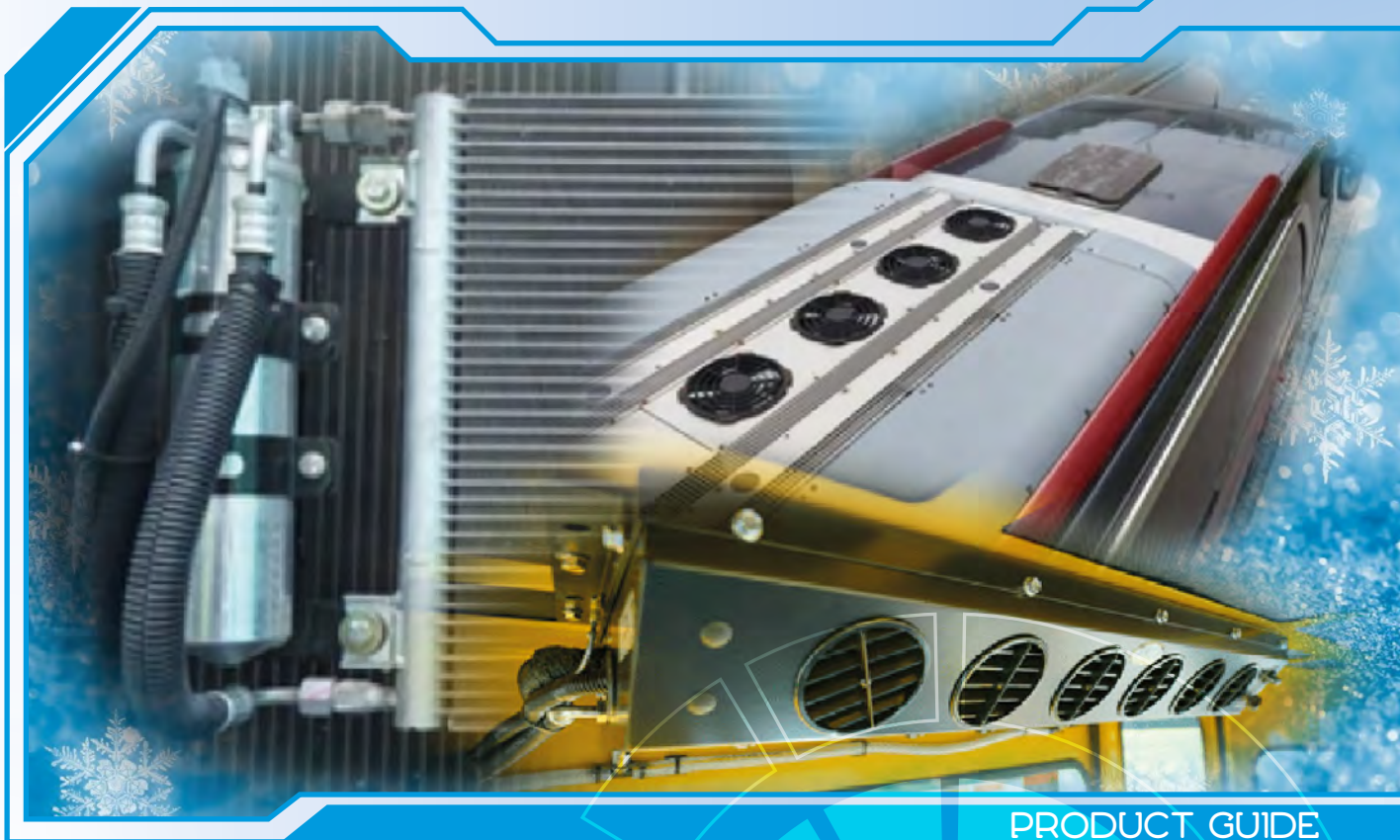

PRODUCT GUIDE

2021

AUTHORISED MANULI AIR CONDITIONING DEALER - AUSTRALIA WIDE
Refrigeration Manuli Hose & fitting Supplier

info@autotechmining.com.au
0412 228 671 - (08) 6118 4152
PERTH , W.A

 **manuli**[®]
REFRIGERATION & COOLING



AUTOTECH MINING

AUTHORISED MANULI AIR CONDITIONING DEALER - AUSTRALIA WIDE
Refrigeration Manuli Hose & fitting Supplier

- Supply Air conditioning Hose Kit
- Liebherr, Cat, Hitachi Diggers
- Sandvik, D65, Pit viper, Sk Drills

info@autotechmining.com.au
0412 228 671 - (08) 6118 4152
PERTH , W.A

Our Mission	2
Innovation	3
Plant Certifications	4
Product Range	5
International Standards	6
Hose Selection Guide	7
Fitting Connection Sizes	8
1 - REFRIGERATION HOSES	
Refrigeration Hoses	11
2 - REFRIGERATION FITTINGS	
FrigoClic Type	14
StatFit Type	19
Star-Crimp Type	23
Fast-Crimp Type	26
Accessories	30
Bespoke Fitting Solutions	33
3 - APPENDICES	
Legend of Symbols	45
Glossary of Terms	45
Hose Size Conversion Chart	46
Assembly Instructions	47
RefriMaster Plus with Clamp	48
RefriMaster Plus with Ferrule	51
UltraStar with Reusable Fittings	53
UltraStar with Crimped Fittings	55

OUR MISSION

Manuli Hydraulics is focused on achieving excellence in the design, manufacture and supply of fluid conveyance solutions, components and associated equipment for high pressure hydraulics, refrigeration and oil and marine applications.

Just some of the application areas where Manuli Hydraulics products are used are:

- Construction and public works
- Underground and open pit mining
- Maintenance services
- Forestry
- Agriculture
- Water blasting and cleaning
- Refrigeration
- Material handling and logistics
- Industrial machines
- Industrial services
- Energy

Manuli Hydraulics Offers:

- Wire spiral reinforced rubber hoses
- Wire braid reinforced rubber hoses
- Textile braid reinforced rubber hoses
- Reinforced thermoplastic hoses
- Hose fitting
- Quick couplings
- Staple-lock fittings, adaptors and valves for underground mining application
- Assembling machines
- Hose assemblies and hose kits for mobile refrigeration systems
- Hose assemblies for water cleaning and water blasting applications
- Hose assemblies for high and very high pressure hydraulics systems
- Other fluid connector

INNOVATION

Manuli Hydraulics R&D activities are based at the Manuli Innovation Centre (MIC) in Bologna, Italy, which oversees the R&D centres in France, Poland, China and the UK. All of our research centres are equipped with advanced design, testing and validation facilities.

The main MIC laboratories feature special rooms and equipment that allow researchers to simulate the most extreme environmental and operational conditions including:

- Heat
- Cold
- Fog
- Fatigue (Impulse testing)
- Hydrostatic testing
- Saline environments
- Vibrations

MIC are responsible for the design and development of every aspect of our product range, from rubber compounds and hose structures, to fitting design and assembly machines. Our global R&D teams are made up of highly skilled international engineers who are dedicated to the development of integrated solutions for Manuli customers. The quality, wide selection of products and cost saving initiatives that our Innovation Centres provide allow us to better support our customers whatever their requirements.

Our Innovation Centres also focus on the development of co-design projects in confidential alliances with Original Equipment Customers. This is an additional benefit to our Partners, whilst the technological cooperation with OEMs helps our engineers to better understand the demanding and ever-evolving requirements of fluid conveying applications. Our focus on customer requirements enhances our capability and expertise in providing complete fluid connector solutions



PLANT CERTIFICATIONS

Quality and sustainable development are the driving forces of all Manuli Hydraulics' activities. Manuli Rubber Industries was the first European hydraulic components manufacturer to achieve the ISO 9001 certification in 1992 and the OHSAS certification in 2005.

The Manuli Group facilities are compliant to ISO 9001 and ISO 14001 and have achieved the Occupational Health and Safety Assessment Series (OHSAS) certifications as the result of it's strong commitment to the preservation of people's health & safety on the work sites.

ISO 9001 CERTIFIED PLANTS

- Manuli Rubber Industries - Italy, Innovation Centre & Headquarters
- Manuli Rubber Industries - Italy, Hydraulic Hoses
- Manuli Rubber Industries - Italy, Oil & Marine Hoses
- Manuli Hydraulics Americas (Chambersburg) - USA, Hose assemblies
- Manuli Hydraulics (Suzhou) - PRC, Hydraulic Hoses
- Manuli Hydraulics (Suzhou) - PRC, Hose assemblies
- Manuli Hydraulics Manufacturing (Radomsko) - Poland, Hydraulic Hoses
- Manuli Hydraulics Polska - Poland, HY Connectors, Refri & A/C systems
- Manuli Hydraulics - UK, Hose assemblies
- Manuli Hydraulics Europe - Czech Rep., Hose assemblies
- Manuli Hydraulics - India, Hose assemblies
- Manuli Hydraulics Korea - S. Korea, Hose assemblies
- Manuli Otim - France, Hose assemblies
- Techmaflex - France, Assembling machines
- Fluiconnecto by Manuli - South Africa
- Fluiconnecto by Manuli - The Netherlands



ISO 14001 CERTIFIED PLANTS

- Manuli Rubber Industries - Italy - Hydraulic Hoses
- Manuli Rubber Industries - Italy - Oil & Marine Hoses
- Manuli Hydraulics (Suzhou) - P.R.C. - Hydraulic Hoses
- Manuli Hydraulics (Suzhou) - P.R.C. - Hose assemblies
- Manuli Hydraulics Polska - Poland - HY Connectors, Refri & A/C systems
- Manuli Hydraulics UK - United Kingdom - Hose assemblies
- Manuli Hydraulics Europe - Czech Rep. - Hose assemblies
- Manuli Hydraulics Korea - Korea - Hose assemblies
- Manuli Hydraulics India - India - Hose assemblies

OHSAS 18001 CERTIFIED PLANTS

- Manuli Hydraulics (Suzhou) - PRC, Hydraulic Hoses
- Manuli Hydraulics (Suzhou) - PRC, Hose assemblies
- Fluiconnecto by Manuli - South Africa



PRODUCT RANGE

The Manuli Hydraulics Refrigeration product range consists of reinforced rubber hoses, fittings, hose assemblies and kits.

Each and every product is designed specifically to meet even the most restrictive requirements for

- **Mobile Air Conditioning** - Air conditioning systems for off-highway industrial vehicles, buses, trains, leisure vehicles and special applications such as emergency vehicles.
- **Mobile Refrigeration** - Refrigeration systems for small-medium vans, refrigerated trucks and refrigerated shipping containers

Manuli Hydraulics also offers both standard crimped fittings as well as field-attachable fittings which allow convenient mounting and disassembly on-site.



INTERNATIONAL STANDARDS

The previous relevant standard was **SAE J2064:2011**, which has since been replaced by:

SAE J3062:2021 - Defines the standard specifications for refrigeration hoses and assemblies

SAE J2064:2021 - Defines the assembly specifications, testing methods and related acceptance criteria

The two standards cover the following areas:

TEST	SAE J2064:2011	SAE J2064:2021	SAE J3062:2021
“Hose structure definition	✓		✓
Permeation Test	✓	✓	✓
Coupling Integrity	✓	✓	✓
Aging Test	✓		✓
Cold Test	✓		✓
Vacuum Flattening	✓		✓
Length Change	✓		✓
Bursting Strength	✓	✓	✓
Proof Test	✓	✓	✓
Extraction Test	✓		✓
Ozone Test	✓		✓
Cleanliness Test	✓	✓	
Moisture Ingression	✓		✓

The two standards categorise hoses types according to the following system:

SAE J2064	DESCRIPTION
TYPE A	Elastomeric, textile reinforcement
TYPE B	Elastomeric, wire (steel) reinforcement
TYPE C	Barrier, textile reinforcement
TYPE D	Thermoplastic, textile reinforcement
TYPE E	Veneer, textile reinforcement
TYPE F	Veneer, barrier, thermoplastic liner
TYPE G	Thermoplastic, textile reinforced, thermoplastic cover

In addition the new standards have introduced a new category for Permeability levels for thermoplastic hoses. This new “Ultra Low Permeability” level is noted as C_u, D_u, E_u, F_u and G_u in the following table:

HOSE TYPE	REFRIGERANT	
	R134a	R1234yf / R152a
A, B	15 kg/m ² /year	18 kg/m ² /year
C, D, E, F, G	5 kg/m ² /year	5 kg/m ² /year
C _u , D _u , E _u , F _u , G _u	1.5 kg/m ² /year	1.5 kg/m ² /year

HOSE SELECTION GUIDE:

- **RefriMaster Plus** - Extremely low permeability rate with a reduced bending radius and improved resistance to kinking. Temperature resistance up to 140°C. Both crimped and field attachable fitting solutions available
- **UltraStar** - Type B hose with the permeability performance of a Type E hose. High mechanical strength, reduced bending radius and an extremely low permeation rate with the benefits of an all rubber hose. Both crimped and field attachable fitting solutions available
- **RefriFast** - Compact dimensions within Type A hoses and outside diameter comparable with reduced barrier hoses. Low weight, easy installation in confined spaces. High flexibility and low bend radius. One-piece crimped solution available.

HOSE	KEY PERFORMANCE	FIELD ATTACHABLE SOLUTION	CRIMPED SOLUTION	REFRIGERANTS
REFRIMASTER PLUS	SAE J3062 / SAE J2064 TYPE E	Insert: FRIGOCLIC + Clamp: C01000 / C01050	Insert: FRIGOCLIC + Ferrule: C00700 / C00750	R134a R404a R407c R1234yf
ULTRASTAR	SAE J3062 / SAE J2064 EXCEEDS TYPE B	Insert: STAR-FIT + Ferrule: K00400	Insert: STAR-CRIMP + Ferrule: C00300	R134a R1234yf
REFRIFAST	SAE J3062 / SAE J2064 TYPE A	-	FAST-CRIMP (One-Piece Fitting)	R134a R1234yf

The following graph illustrates how the permeability of each hose compares to the applicable permeability level categories as defined in SAE J3062:2021 and SAE J2064 :2021

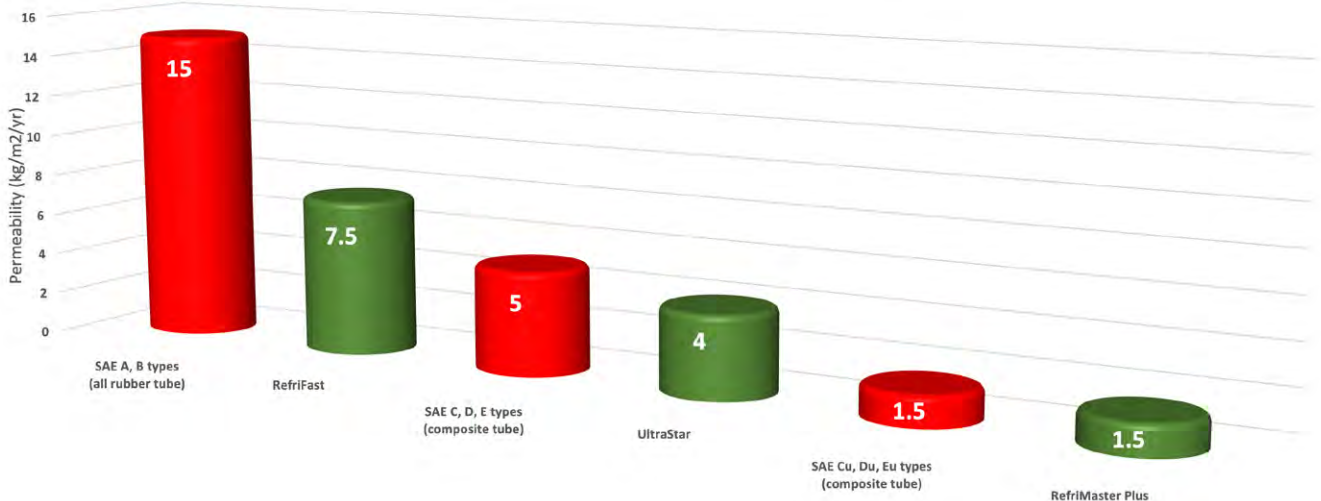

FITTING CONNECTION SIZES

DASH	SAE	SAE 45° FLARE FITTING THREAD	JIC 37° FLARE FITTING THREAD	FEMALE O-RING & MALE O-RING SEAT FITTING THREAD	MALE O-RING FITTING THREAD	O-RING METRIC FITTING THREAD	ORS FACE SEAL FITTING	DIN 3901/3902 FITTING THREAD
-04	1/4"	7/16"-20-UNF	7/16"-20-UNF	-	-	-	9/16"-18-UNF	-
-06	3/8"	5/8"-18-UNF	9/16"-18-UNF	5/8"-18-UNF	5/8"-18-UNF	M16 x 1.5	11/16"-16-UN	-
-08	1/2"	3/4"-16-UNF	3/4"-16-UNF	3/4"-16-UNF	3/4"-18-UNS	M20 x 1.5	13/16"-16-UN	M18 x 1.5
-10	5/8"	7/8"-14-UNF	7/8"-14-UNF	7/8"-14-UNF	7/8"-18-UNS	M24 x 1.5	1"-14-UNS	M22 x 1.5
-11	-	-	-	1"-14-UNS	-	-	-	-
-12	3/4"	1.1/16"-14-UNS	1.1/16"-12-UNF	1.1/16"-14-UNS	1.1/16"-16-UN	M27 x 2	1.3/16"-12-UN	M26 x 1.5
-16	1"	1.5/16"-14-UNF	1.5/16"-12-UNF	1.5/16"-14-UNF	-	-	1.7/16"-12-UN	M30 x 2
-18	-	-	-	-	-	-	-	M36 x 2
-20	1.1/4"	1.5/8"-12-UNF	1.5/8"-12-UN	-	-	-	1.11/16"-12-UN	-
-22	-	-	-	-	-	-	-	M45 x 2
-24	1.1/2"	-	1.7/8"-12-UN	-	-	-	2"-12-UN	-

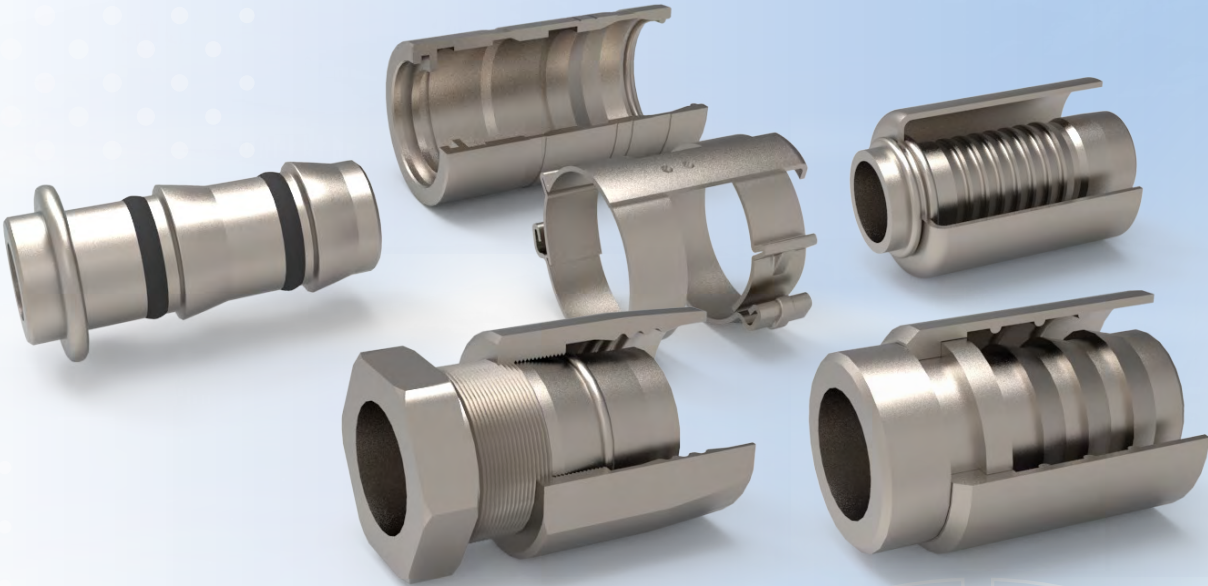



AUTOTECH

MINING

ULTRASTAR

INNOVATIVE RUBBER CONSTRUCTION, SUPERIOR BARRIER TYPE IMPERMEABILITY



TECHNICAL DATA

PART REF.	HOSE SIZE			R.O.D		O.D		MAX. W.P		BURST		MIN. BEND		WEIGHT		FITTINGS	
	DN	dash	inch	mm	inch	mm	inch	bar	psi	bar	psi	mm	inch	g/m	lb/ft	Std 1	Std 2
H01133005*	5	-4	3/16"	11,2	0,44	13,0	0,51	35	500	150	2170	85	3,35	217	0,15	SC+C00300-04	SF+K00400-04
H01133008*	8	-6	5/16"	15,4	0,61	17,2	0,68	35	500	150	2170	85	3,35	336	0,23	SC+C00300-06	SF+K00400-06
H01133010*	10	-8	13/32"	17,5	0,69	19,3	0,76	35	500	150	2170	95	3,74	385	0,26	SC+C00300-08	SF+K00400-08
H01133012*	12	-10	1/2"	21,6	0,85	23,4	0,92	35	500	150	2170	115	4,53	533	0,36	SC+C00300-10	SF+K00400-10
H01133016*	16	-12	5/8"	25,5	1,00	27,3	1,07	35	500	150	2170	135	5,31	676	0,45	SC+C00300-12	SF+K00400-12
H01133022*	22	-16	7/8"	29,5	1,16	31,5	1,24	35	500	150	2170	100	3,94	724	0,49	SC+C00300-16	SF+K00400-16
H01133028*	28	-20	1.1/8"	36,1	1,42	38,1	1,50	35	500	150	2170	120	4,72	900	0,60	SC+C00300-20	SF+K00400-20
H01133035*	35	-24	1.3/8"	42,8	1,69	44,8	1,76	35	500	150	2170	120	4,72	1214	0,82		SF+K00400-24

KEY FEATURES

- Very low permeability to refrigerant fluids (performance with R134a < 5 kg/m²/yr), equivalent to type E hoses
- High flexibility

APPLICATIONS & FLUIDS

- Bus and off-highway equipment air-conditioning systems
- Recommended lubricants: PAG, POE
- Not recommended with refrigerant gases using mineral oils as lubricants
- Refrigerants: R134a; R1234yf

CONTINUOUS SERVICE TEMPERATURE RANGE

-40 °C, -40 °F
125 °C, 257 °F

TUBE

Unique molecular barrier compound made from synthetic rubber (CIIR) and advanced materials

REINFORCEMENT

One steel wire braid

COVER

High temperature and environment resistant synthetic rubber

APPLICABLE SPECS

SAE J3062 Type B Class I (meets the performance of Type E); SAE J2064

TYPE APPROVALS

CU-TR

REMARKS



- *Guaranteed performance only with Manuli fittings*
- *Ask Manuli Hydraulics about other refrigerants and lubricants*

REFRIMASTER PLUS

UNIVERSAL REFRIGERANTS HOSE WITH ULTRA LOW PERMEABILITY



TECHNICAL DATA

PART REF.	HOSE SIZE			R.O.D		O.D		MAX. W.P		BURST		MIN. BEND		WEIGHT		FITTINGS	
	DN	dash	inch	mm	inch	mm	inch	bar	psi	bar	psi	mm	inch	g/m	lb/ft	Std 1	Std 2
H09071008*	8	-6	5/16"			12,9	0,51	35	500	250	3620	40	1,57	80	0,05	FC+C00700-06	FC+C01000-06
H09071010*	10	-8	13/32"			16,2	0,64	35	500	250	3620	50	1,97	152	0,10	FC+C00700-08	FC+C01000-08
H09071013*	13	-10	1/2"			20,6	0,81	35	500	150	2170	70	2,76	235	0,16	FC+C00750-10	FC+C01050-10
H09071016*	16	-12	5/8"			24,0	0,94	35	500	150	2170	80	3,15	285	0,19	FC+C00750-12	FC+C01050-12
H09071022*	22	-16	7/8"			31,0	0,94	35	500	150	2170	120	4,72	405	0,27	FC+C00750-16	

KEY FEATURES

- Universal hose, compatible with the most common compressor lubricants
- Low permeability to refrigerant fluid
- Field attachable and crimped solutions available with Frigoclic® insert
- Small bending radius
- Improved resistance to kinking

APPLICATIONS & FLUIDS

- Air conditioning systems (off-highway machines, buses, etc.)
- Mobile refrigeration systems
- Compatibility with the most common compressor lubricants (PAG, POE, mineral oils)
- Compatibility with a wide range of refrigerants (R134a, R404A, R407C, R1234yf)

CONTINUOUS SERVICE TEMPERATURE RANGE

-40 °C, -40 °F
125 °C, 257 °F

TUBE

High temperature resistant thermoplastic (PA) veneer

REINFORCEMENT

One textile braid

COVER

High temperature and environment resistant synthetic rubber (EPDM)

APPLICABLE SPECS

SAE J3062 Type E_u Class I; SAE J2064

TYPE APPROVALS

CU-TR

REMARKS



- *Guaranteed performance only with Manuli fittings*
- *Ask Manuli Hydraulics about other refrigerants and lubricants*

REFRIFAST

COMPACT, LIGHT, FLEXIBLE HOSE FOR GENERAL AIR-CON APPLICATIONS



TECHNICAL DATA

PART REF.	HOSE SIZE			R.O.D		O.D		MAX. W.P		BURST		MIN. BEND		WEIGHT		FITTINGS	
	DN	dash	inch	mm	inch	mm	inch	bar	psi	bar	psi	mm	inch	g/m	lb/ft	Std 1	Std 2
H09068008*	8	-6	5/16"			15,5	0,61	35	500	150	2170	30	1,18	165	0,11	OPC-06	
H09068010*	10	-8	13/32"			18,0	0,71	35	500	150	2170	50	1,97	200	0,13	OPC-08	
H09068012*	13	-10	1/2"			20,0	0,79	35	500	150	2170	60	2,36	230	0,15	OPC-10	
H09068016*	16	-12	5/8"			23,5	0,93	35	500	150	2170	80	3,15	295	0,20	OPC-12	

KEY FEATURES

- Higher compact dimensions within Type A hoses, and outside diameter comparable to reduced barrier hoses
- Low weight
- Easy installation in constrained spaces
- High flexibility and low bend radii
- Low refrigerant permeability and moisture ingress

APPLICATIONS & FLUIDS

- Bus and off-highway equipment air-conditioning systems
- Recommended lubricants: PAG, POE
- Not recommended with refrigerant gases using mineral oils as lubricants
- Refrigerants: R134a; R1234yf

CONTINUOUS SERVICE TEMPERATURE RANGE

-40 °C, -40 °F
125 °C, 257 °F

TUBE

CIIR - Low refrigerant fluid permeability and compatibility with the most common compressor lubricants

REINFORCEMENT

One textile braid

COVER

High temperature and environment resistant synthetic rubber

APPLICABLE SPECS

SAE J3062 Type A Class I; SAE J2064

TYPE APPROVALS

CU-TR

REMARKS



- *Guaranteed performance only with Manuli fittings*
- *Ask Manuli Hydraulics about other refrigerants and lubricants*

REFRIGERATION HOSES

DN	5	8	10	13	16	22	28	35	51	60
Inch	3/16"	5/16"	13/32"	1/2"	5/8"	7/8"	1.1/8"	1.3/8"	2"	2.3/8"
dash	-04	-06	-08	-10	-12	-16	-20	-24	-32	-38

REFRIMASTER PLUS		✓	✓	✓	✓	✓				
ULTRASTAR	✓	✓	✓	✓	✓	✓	✓	✓		
REFRIFAST		✓	✓	✓	✓					

FRIGOCLIC



DN	5	8	10	13	16	22	28	35
Inch	3/16"	5/16"	13/32"	1/2"	5/8"	7/8"	1.1/8"	1.3/8"
dash	-04	-06	-08	-10	-12	-16	-20	-24

C00700		REFRIMASTER PLUS FERRULE		✓	✓					
C00750		REFRIMASTER PLUS FERRULE				✓	✓	✓		
C01000		REFRIMASTER PLUS CLAMP		✓	✓					
C01050		REFRIMASTER PLUS CLAMP				✓	✓			
C42610		45° SAE STRAIGHT FEMALE		-04 -06 -08	-06 -08	-08 -10	-10 -12			
C42640		45° SEA FEMALE 45° ELBOW		-04 -06	-08	-08 -10	-10 -10			
C42690		45° SEA FEMALE 90° ELBOW		-04 -06	-06 -08	-08 -10	-10 -10			
C47910		STRAIGHT O-RING FEMALE		-06 -08	-06 -08 -08105 -10 -11	-08 -08103 -10 -11 -12	-10 -11 -12	-10 -12		
C47915		STRAIGHT O-RING FEMALE WITH HIGH PRESSURE VALVE		-06	-08 -11	-08 -10 -11	-10			
C47913		STRAIGHT O-RING FEMALE WITH HIGH PRESSURE VALVE FOR R1234YF		-06	-08 -11	-08 -10 -11	-10			

NOTE: Dash numbers in table indicate size of termination end or additional tail sizes

FRIGOCLIC



DN	5	8	10	13	16	22	28	35
Inch	3/16"	5/16"	13/32"	1/2"	5/8"	7/8"	1.1/8"	1.3/8"
dash	-04	-06	-08	-10	-12	-16	-20	-24

C47916		STRAIGHT O-RING FEMALE WITH LOW PRESSURE VALVE		-06	-08	-10 -11	-10 -11 -11143	-10 -12		
C47914		STRAIGHT O-RING FEMALE WITH LOW PRESSURE VALVE FOR R1234YF		-06	-08	-10 -11	-10 -11 -11143	-10 -12		
C47912		STRAIGHT O-RING FEMALE 1/4" SAE CHARGE VALVE		-06	-08	-08 -10	-10			
C47940		O-RING FEMALE 45° ELBOW		-06 -08	-06 -08 -08054 -11	-08 -10 -10055 -11 -12	-10 -10/01 -10055 -11 -12	-12		
C47945		O-RING FEMALE 45° ELBOW WITH HIGH PRESSURE VALVE		-06	-08 -11	-08 -11 -12				
C47943		O-RING FEMALE 45° ELBOW WITH HIGH PRESSURE VALVE FOR R1234YF		-06	-08 -11	-08 -11 -12				
C47946		O-RING FEMALE 45° ELBOW WITH LOW PRESSURE VALVE				-10 -11	-10 -11			
C47944		O-RING FEMALE 45° ELBOW WITH LOW PRESSURE VALVE FOR R1234YF				-10 -11	-10 -11			
C47942		O-RING FEMALE 45° ELBOW WITH 1/4" SAE CHARGE VALVE		-06	-08	-10				
C47990		O-RING FEMALE 90° ELBOW		-06 -08 -10	-06 -08 -08037 -08043 -08100 -10 -10050 -11 -11049 -11065	-08 -10 -11 -12	-10 -11 -12	-10 -12		
C47995		O-RING FEMALE 90° ELBOW WITH HIGH PRESSURE VALVE		-06	-08 -08030 -11 -11059	-08 -10 -11				
C47993		O-RING FEMALE 90° ELBOW WITH HIGH PRESSURE VALVE FOR R1234YF		-06	-08 -08030 -11 -11059	-08 -10 -11				

NOTE: Dash numbers in table indicate size of termination end or additional tail sizes

FRIGOCLIC



DN	5	8	10	13	16	22	28	35
Inch	3/16"	5/16"	13/32"	1/2"	5/8"	7/8"	1.1/8"	1.3/8"
dash	-04	-06	-08	-10	-12	-16	-20	-24

C47996		O-RING FEMALE 90° ELBOW WITH LOW PRESSURE VALVE			-08	-08 -10 -11	-10 -11 -1049 -12	-10 -12		
C47994		O-RING FEMALE 90° ELBOW WITH LOW PRESSURE VALVE FOR R1234YF			-08	-08 -10 -11	-10 -11 -11049 -12	-10 -12		
C47992		O-RING FEMALE 90° ELBOW WITH 1/4" SAE CHARGE VALVE		-06	-08	-10	-10 -12			
C47980		SHORT VERSION O-RING FEMALE 90° ELBOW		-06	-08 -11	-08 -10 -11	-10 -11 -12			
C47985		SHORT VERSION O-RING FEMALE 90° ELBOW WITH HIGH PRESSURE VALVE		-06	-08 -11	-10 -11	-11			
C47983		SHORT VERSION O-RING FEMALE 90° ELBOW WITH HIGH PRESSURE VALVE FOR R1234YF		-06	-08 -11	-10 -11	-11			
C47986		SHORT VERSION O-RING FEMALE 90° ELBOW WITH LOW PRESSURE VALVE				-10 -11	-10 -11	-11		
C47984		SHORT VERSION O-RING FEMALE 90° ELBOW WITH LOW PRESSURE VALVE FOR R1234YF				-10 -11	-10 -11	-11		
C47982		SHORT VERSION O-RING FEMALE 90° ELBOW 1/4" SAE CHARGE VALVE			-11	-10	-11			
C38010		STRAIGHT O-RING MALE		-06	-06 -08 -10	-10 -12	-10 -12	-10 -12		
C38040		O-RING MALE 45° ELBOW		-06	-06 -08	-10	-10 -12			
C38090		O-RING MALE 90° ELBOW		-06	-06 -08	-08 -10	-10 -12	-10 -12		
C47610		STRAIGHT FITTING FOR EXPANSION VALVE		-06	-06	-10 -12	-12			

NOTE: Dash numbers in table indicate size of termination end or additional tail sizes

FRIGOCLIC



DN	5	8	10	13	16	22	28	35
Inch	3/16"	5/16"	13/32"	1/2"	5/8"	7/8"	1.1/8"	1.3/8"
dash	-04	-06	-08	-10	-12	-16	-20	-24

C47640		FITTING FOR EXPANSION VALVE 45° ELBOW		-06	-06	-10 -10024 -12	-10 -12			
C47690		FITTING FOR EXPANSION VALVE 90° ELBOW		-06 -06040 -06046 -06050 -06087	-06 -08	-10 -12	-10 -12			
C30010		STRAIGHT CONNECTION FITTINGS		-06 -08	-08	-10	-12	-16		
C300T0		"T" CONNECTION FITTING - 3 WAYS CONNECTION		-06-06 -06-08	-08-08 -08-10 -10-10 -10-12	-10-10 -10-12 -12-12	-10-10 -12-12			
C300Y0		"Y" CONNECTION FITTING - 3 WAYS CONNECTION		-06-06	-08-08	-10-10	-12-12			
C300H0		"H" CONNECTION FITTINGS - 3 WAYS CONNECTION		-06-08 -06-10 -10-06	-08-08 -08-06	-10-06 -10-10 -10-1001 -10-12 -12-10	-12-06 -12-10 -12-12			
C30015		STRAIGHT CONNECTION FITTING WITH HIGH PRESSURE VALVE		-06	-08	-10	-12			
C30013		STRAIGHT CONNECTION FITTING WITH HIGH PRESSURE VALVE FOR R1234YF		-06	-08	-10	-12			
C30016		STRAIGHT CONNECTION FITTING WITH LOW PRESSURE VALVE			-08	-10	-12	-16		
C30014		STRAIGHT CONNECTION FITTING WITH LOW PRESSURE VALVE FOR R1234YF			-08	-10	-12	-16		
C30012		STRAIGHT CONNECTION FITTING 1/4" SAE CHARGE VALVE		-06	-08	-10	-12			
C30040		CONNECTION FITTING 45° ELBOW		-06	-08	-10	-12			
C30090		CONNECTION FITTING 90° ELBOW		-06	-08	-10	-12 -12/01	-16		

NOTE: Dash numbers in table indicate size of termination end or additional tail sizes

FRIGOCLIC



DN	5	8	10	13	16	22	28	35
Inch	3/16"	5/16"	13/32"	1/2"	5/8"	7/8"	1.1/8"	1.3/8"
dash	-04	-06	-08	-10	-12	-16	-20	-24

C42410		STRAIGHT ORS FLAT SEAL FEMALE		-04 -06	-08	-08 -10	-10 -12	-16		
C42440		ORS FLAT SEAL FEMALE 45° ELBOW		-04 -06 -08	-08	-08 -10	-10 -12			
C42490		ORS FLAT SEAL FEMALE 90° ELBOW		-04 -06 -06028 -08	-08	-08 -10	-10 -12	-16		
C37910		STRAIGHT MALE WITH O-RING SEAT		-06	-06 -08 -10	-10	-10 -12			
C37910... W...		STRAIGHT MALE WITH O-RING SEAT WITH COUNTER NUT		-06W24	-08W25		-12W32			
C37910... W...Q		STRAIGHT MALE WITH O-RING SEAT WITH COUNTER NUT AND Q-RING		-06W24Q		-10W29Q				
C37940		MALE WITH O-RING SEAT 45° ELBOW		-06	-06					
C37990		MALE WITH O-RING SEAT 90° ELBOW		-06	-06 -08	-08				
C37990... W...Q		MALE WITH O-RING SEAT WITH COUNTER NUT AND Q-RING 90° ELBOW		-06W24Q		-10W30Q				

NOTE: Dash numbers in table indicate size of termination end or additional tail sizes

STAR-FIT



DN	5	8	10	13	16	22	28	35
Inch	3/16"	5/16"	13/32"	1/2"	5/8"	7/8"	1.1/8"	1.3/8"
dash	-04	-06	-08	-10	-12	-16	-20	-24

K00400		STAR-FIT FERRULE	✓	✓	✓	✓	✓	✓	✓
K42610		45° SAE STRAIGHT FEMALE	-04 -04H00	-06 -06H00	-08 -10 -08H00	-08 -10 -10H00	-10 -12 -12H00	-10 -12 -16 -16H00	-20
K42640		45° SAE FEMALE 45° ELBOW	-04	-06	-08	-10	-08 -10 -12	-10 -12 -16	
K42690		45° SAE FEMALE 90° ELBOW	-04	-06	-06 -08	-08 -10	-08 -10 -12	-10 -12 -12/01 -16	
K32610		STRAIGHT 45° SAE FLARE MALE	-04	-06	-08	-10	-12	-16	-20
K47910		STRAIGHT O-RING FEMALE		-06	-06 -08	-10	-08 -10 -12	-10 -12 -16	
K47915		STRAIGHT O-RING FEMALE WITH HIGH PRESSURE VALVE			-08	-08	-10		
K47913		STRAIGHT O-RING FEMALE WITH HIGH PRESSURE VALVE FOR R1234YF			-08	-08	-10		
K47916		STRAIGHT O-RING FEMALE WITH LOW PRESSURE VALVE					-10	-10 -12	
K47914		STRAIGHT O-RING FEMALE WITH LOW PRESSURE VALVE FOR R1234YF					-10	-10 -12	
K47912		STRAIGHT O-RING FEMALE WITH 1/4" SAE CHARGE VALVE		-06	-08	-10	-10		
K47940		O-RING FEMALE 45° ELBOW		-06	-08	-08 -10 -11	-10 -11 -12	-10 -12	
K47945		O-RING FEMALE 45° ELBOW WITH HIGH PRESSURE VALVE			-08		-10		

NOTE: Dash numbers in table indicate size of termination end or additional tail sizes

STAR-FIT



DN	5	8	10	13	16	22	28	35
Inch	3/16"	5/16"	13/32"	1/2"	5/8"	7/8"	1.1/8"	1.3/8"
dash	-04	-06	-08	-10	-12	-16	-20	-24

K47943		O-RING FEMALE 45° ELBOW WITH HIGH PRESSURE VALVE FOR R1234YF			-08	-10		
K47990		O-RING FEMALE 90° ELBOW		-06	-06 -08	-10	-08 -10 -11 -12 -10113 -10122 -12	-12 -12087 -12124
K47995		O-RING FEMALE 90° ELBOW WITH HIGH PRESSURE VALVE			-06 -08	-08	-10	-10
K47993		O-RING FEMALE 90° ELBOW WITH HIGH PRESSURE VALVE FOR R1234YF			-06 -08	-08	-10	-10
K47996		O-RING FEMALE 90° ELBOW WITH LOW PRESSURE VALVE					-10	-10 -12 -12
K47994		O-RING FEMALE 90° ELBOW WITH LOW PRESSURE VALVE FOR R1234YF					-10	-10 -12 -12
K47992		O-RING FEMALE 90° ELBOW WITH 1/4" SAE CHARGE VALVE					-10	-12
K38010		STRAIGHT O-RING MALE		-06	-06 -08	-10		
K38040		O-RING MALE 45° ELBOW		-06	-06 -08	-10	-10	
K38090		O-RING MALE 90° ELBOW		-06	-06 -08	-10	-10	
K41510		STRAIGHT 24° DIN FLARE O-RING OGIVAL FEMALE			-18	-26	-26 -30	-30 -36 -36 -45
K41540		24° DIN FLARE O-RING OGIVAL FEMALE 45° ELBOW					-26 -30	-30 -36 -36
K41590		24° DIN FLARE O-RING OGIVAL FEMALE 90° ELBOW			-18 -26		-26 -30	-30 -30125 -36 -36

NOTE: Dash numbers in table indicate size of termination end or additional tail sizes

STAR-FIT



DN	5	8	10	13	16	22	28	35
Inch	3/16"	5/16"	13/32"	1/2"	5/8"	7/8"	1.1/8"	1.3/8"
dash	-04	-06	-08	-10	-12	-16	-20	-24

K43710		STRAIGHT FLANGE FITTING							-16	-16	-16
K43740		FLANGE FITTING 45° ELBOW				-16	-16	-16	-16	-16	-16/01
K43790		FLANGE FITTING 90° ELBOW						-16	-16	-16	-16
						-16085	-16085	-16097	-16105	-16105	-16117
						-16079	-20	-20	-24		
K42410		STRAIGHT ORS FLAT SEAL FEMALE	-04	-06	-08	-10	-12	-16	-20	-20	-24
						-16079	-20	-20	-24		
K42440		ORS FLAT SEAL FEMALE 45° ELBOW	-04	-06	-08	-10	-12	-16	-20	-16	-24
						-08	-16	-20	-20	-20	
K42490		ORS FLAT SEAL FEMALE 90° ELBOW	-04	-06	-08	-10	-12	-16	-20	-16	-20
								-20	-20		
K30010		STRAIGHT CONNECTION FITTING	-04	-06	-08	-10	-12	-16	-20		
K30015		STRAIGHT CONNECTION FITTING WITH HIGH PRESSURE VALVE			-08	-10					
K30013		STRAIGHT CONNECTION FITTING WITH HIGH PRESSURE VALVE FOR R1234YF			-08	-10					
K30016		STRAIGHT CONNECTION FITTING WITH LOW PRESSURE VALVE				-10	-12	-16			
K30014		STRAIGHT CONNECTION FITTING WITH LOW PRESSURE VALVE FOR R1234YF				-10	-12	-16			
K42510		JIC 37° STRAIGHT FEMALE FITTING						-12	-16	-20	
								-16			
K42540		JIC 37° FEMALE FITTING 45° ELBOW						-16			

NOTE: Dash numbers in table indicate size of termination end or additional tail sizes

STAR-FIT



DN	5	8	10	13	16	22	28	35
Inch	3/16"	5/16"	13/32"	1/2"	5/8"	7/8"	1.1/8"	1.3/8"
dash	-04	-06	-08	-10	-12	-16	-20	-24

K42590		JIC 37° FEMALE FITTING 90° ELBOW					-16	-20	
K31110		STRAIGHT 24° MALE DIN				-26	-30 -30111	-36 -36150	
K47980		SHORT VERSION O-RING FEMALE 90° ELBOW		-11	-11	-11			
K47985		SHORT VERSION O-RING FEMALE 90° ELBOW WITH HIGH PRESSURE VALVE		-11		-11			
K47983		SHORT VERSION O-RING FEMALE 90° ELBOW WITH HIGH PRESSURE VALVE FOR R1234YF		-11		-11			
K47986		SHORT VERSION O-RING FEMALE 90° ELBOW WITH LOW PRESSURE VALVE		-08	-10 -11	-11	-11		
K47984		SHORT VERSION O-RING FEMALE 90° ELBOW WITH LOW PRESSURE VALVE FOR R1234YF		-08	-10 -11	-11	-11		
K47982		SHORT VERSION O-RING FEMALE 90° ELBOW WITH 1/4" SAE CHARGE VALVE			-08 -11	-08	-10 -11		

NOTE: Dash numbers in table indicate size of termination end or additional tail sizes

STAR-CRIMP



DN	5	8	10	13	16	22	28	35
Inch	3/16"	5/16"	13/32"	1/2"	5/8"	7/8"	1.1/8"	1.3/8"
dash	-04	-06	-08	-10	-12	-16	-20	-24

C00300		STAR-CRIMP FERRULE	✓	✓	✓	✓	✓	✓	
C22610		45° SAE STRAIGHT FEMALE	-04	-04 -06	-08	-10	-10 -12	-16	
C22640		45° SAE FEMALE 45° ELBOW	-04	-04 -06	-08	-10 -12	-10 -12		
C22690		45° SAE FEMALE 90° ELBOW	-04	-04 -06	-06 -08	-10 -12	-10 -12	-10 -16	
C27910		STRAIGHT O-RING FEMALE		-06	-06 -08	-08 -10	-10 -12	-10 -12	-16
C27915		STRAIGHT O-RING FEMALE WITH HIGH PRESSURE VALVE			-08 -11		-12		
C27913		STRAIGHT O-RING FEMALE WITH HIGH PRESSURE VALVE FOR R1234YF			-08 -11		-12		
C27916		STRAIGHT O-RING FEMALE WITH LOW PRESSURE VALVE					-10	-12	
C27914		STRAIGHT O-RING FEMALE WITH LOW PRESSURE VALVE FOR R1234YF					-10	-12	
C27940		O-RING FEMALE 45° ELBOW		-06 -06030	-08 -11	-08 -10	-10 -11 -12	-12	
C27946		O-RING FEMALE 45° ELBOW WITH LOW PRESSURE VALVE				-10	-10		
C27944		O-RING FEMALE 45° ELBOW WITH LOW PRESSURE VALVE FOR R1234YF				-10	-10		
C27990		O-RING FEMALE 90° ELBOW		-06 -06036 -06060 -10	-08 -08053	-06 -08 -10	-10 -12	-10 -12	

NOTE: Dash numbers in table indicate size of termination end or additional tail sizes

STAR-CRIMP



DN	5	8	10	13	16	22	28	35
Inch	3/16"	5/16"	13/32"	1/2"	5/8"	7/8"	1.1/8"	1.3/8"
dash	-04	-06	-08	-10	-12	-16	-20	-24

C23790		FLANGE FITTING 90° ELBOW							-16 -16085	-16 -16097	
C22410		STRAIGHT ORS FLAT SEAL FEMALE				-08 -10			-16	-20	
C22440		ORS FLAT SEAL FEMALE 45° ELBOW				-10			-16	-20	
C22490		ORS FLAT SEAL FEMALE 90° ELBOW				-10			-16	-20	
C10016		STRAIGHT CONNECTION FITTING WITH LOW PRESSURE VALVE							-16		
C10014		STRAIGHT CONNECTION FITTING WITH LOW PRESSURE VALVE FOR R1234YF							-16		
C10015		STRAIGHT CONNECTION FITTING WITH HIGH PRESSURE VALVE				-08			-12		
C10013		STRAIGHT CONNECTION FITTING WITH HIGH PRESSURE VALVE FOR R1234YF				-08			-12		
C10090		CONNECTION 90° ELBOW			-06				-16		

NOTE: Dash numbers in table indicate size of termination end or additional tail sizes

FAST-CRIMP



DN	5	8	10	13	16	22	28	35
Inch	3/16"	5/16"	13/32"	1/2"	5/8"	7/8"	1.1/8"	1.3/8"
dash	-04	-06	-08	-10	-12	-16	-20	-24

OPC10010		STRAIGHT CONNECTION FITTING		-06	-08	-10	-12			
OPC10015		STRAIGHT CONNECTION FITTING WITH HIGH PRESSURE VALVE		-06	-08					
OPC10016		STRAIGHT CONNECTION FITTING WITH LOW PRESSURE VALVE				-10	-12			
OPC10013		STRAIGHT CONNECTION FITTING WITH HIGH PRESSURE VALVE FOR R1234YF		-06	-08					
OPC10014		STRAIGHT CONNECTION FITTING WITH LOW PRESSURE VALVE FOR R1234YF				-10	-12			
OPC10090		CONNECTION 90° ELBOW		-06	-08	-10				
OPC17910		STRAIGHT MALE WITH O-RING SEAT		-06	-08	-10 -10074	-12			
OPC17910- ...W...		STRAIGHT MALE WITH O-RING SEAT WITH COUNTER NUT			-06W21 -06W24	-08W25	-12W32			
OPC17910- ...W...Q		STRAIGHT MALE WITH O-RING SEAT WITH COUNTER NUT AND Q-RING			-06W24Q		-10W29Q			
OPC17990		MALE WITH O-RING SEAT 90° ELBOW			-06 -06035 -06050 -06065					
OPC17990- ...W...Q		MALE WITH O-RING SEAT WITH COUNTER NUT AND Q-RING 90° ELBOW			-06W24Q		-10W30Q			
OPC18010		STRAIGHT O-RING MALE		-06	-08	-10	-10 -10/01 -12			
OPC18040		O-RING MALE 45° ELBOW		-06	-08	-10	-10			

NOTE: Dash numbers in table indicate size of termination end or additional tail sizes

FAST-CRIMP



DN	5	8	10	13	16	22	28	35
Inch	3/16"	5/16"	13/32"	1/2"	5/8"	7/8"	1.1/8"	1.3/8"
dash	-04	-06	-08	-10	-12	-16	-20	-24

OPC18090		O-RING MALE 90° ELBOW		-06	-08	-10	-10			
OPC1C310		STRAIGHT CONNECTION FITTING		-06	-08	-10	-12			
OPC22610		45° SAE STRAIGHT FEMALE		-06	-08	-10	-12			
OPC22640		45° SAE FEMALE 45° ELBOW		-06	-08	-10				
OPC22690		45° SAE FEMALE 90° ELBOW		-06	-08	-10				
OPC27610		STRAIGHT FITTING FOR EXPANSION VALVE		-06		-12				
OPC27640		FITTING FOR EXPANSION VALVE 45° ELBOW		-06		-12	-12			
OPC27690		FITTING FOR EXPANSION VALVE 90° ELBOW		-06 -06046 -06087		-12 -12052 -12081	-12			
OPC27695		FITTING FOR EXPANSION VALVE 90° ELBOW WITH HIGH PRESSURE VALVE		-06						
OPC27693		FITTING FOR EXPANSION VALVE 90° ELBOW WITH HIGH PRESSURE VALVE FOR R1234YF		-06						
OPC27910		STRAIGHT O-RING FEMALE		-06 -08	-06 -08 -11	-10 -10078 -11 -11076	-10 -10079 -11 -12			
OPC27912		STRAIGHT O-RING FEMALE WITH 1/4" SAE CHARGE VALVE				-11	-11			
OPC27915		STRAIGHT O-RING FEMALE WITH HIGH PRESSURE VALVE		-06	-08 -11					

NOTE: Dash numbers in table indicate size of termination end or additional tail sizes

FAST-CRIMP



DN	5	8	10	13	16	22	28	35
Inch	3/16"	5/16"	13/32"	1/2"	5/8"	7/8"	1.1/8"	1.3/8"
dash	-04	-06	-08	-10	-12	-16	-20	-24

OPC27913		STRAIGHT O-RING FEMALE WITH HIGH PRESSURE VALVE FOR R1234YF		-06	-08 -11					
OPC27916		STRAIGHT O-RING FEMALE WITH LOW PRESSURE VALVE				-10 -11				
OPC27914		STRAIGHT O-RING FEMALE WITH LOW PRESSURE VALVE FOR R1234YF				-10 -11				
OPC27940		O-RING FEMALE 45° ELBOW		-06	-08 -11	-10 -11	-10 -11			
OPC27945		O-RING FEMALE 45° ELBOW WITH HIGH PRESSURE VALVE		-06	-08 -11					
OPC27943		O-RING FEMALE 45° ELBOW WITH HIGH PRESSURE VALVE FOR R1234YF		-06	-08 -11					
OPC27946		O-RING FEMALE 45° ELBOW WITH LOW PRESSURE VALVE				-10 -11	-10			
OPC27944		O-RING FEMALE 45° ELBOW WITH LOW PRESSURE VALVE FOR R1234YF				-10 -11	-10			
OPC27980		SHORT VERSION O-RING FEMALE 90° ELBOW		-06	-08 -10	-10 -11	-10 -11			
OPC27985		SHORT VERSION O-RING FEMALE 90° ELBOW WITH HIGH PRESSURE VALVE		-06	-08 -11					
OPC27983		SHORT VERSION O-RING FEMALE 90° ELBOW WITH HIGH PRESSURE VALVE FOR R1234YF		-06	-08 -11					
OPC27986		SHORT VERSION O-RING FEMALE 90° ELBOW WITH LOW PRESSURE VALVE				-10 -11	-10 -11			
OPC27984		SHORT VERSION O-RING FEMALE 90° ELBOW WITH LOW PRESSURE VALVE FOR R1234YF				-10 -11	-10 -11			

NOTE: Dash numbers in table indicate size of termination end or additional tail sizes

FAST-CRIMP



DN	5	8	10	13	16	22	28	35
Inch	3/16"	5/16"	13/32"	1/2"	5/8"	7/8"	1.1/8"	1.3/8"
dash	-04	-06	-08	-10	-12	-16	-20	-24

OPC27990		O-RING FEMALE 90° ELBOW		-06 -06032 -06040 -06044 -06046	-06 -08 -08038 -08053 -08085 -11	-10 -11 -12				
OPC27992		O-RING FEMALE 90° ELBOW WITH 1/4" SAE CHARGE VALVE		-06						
OPC27995		O-RING FEMALE 90° ELBOW WITH HIGH PRESSURE VALVE		-06	-08 -11	-10	-10			
OPC27993		O-RING FEMALE 90° ELBOW WITH HIGH PRESSURE VALVE FOR R1234YF		-06	-08 -11	-10	-10			
OPC27996		O-RING FEMALE 90° ELBOW WITH LOW PRESSURE VALVE				-10 -11	-10 -12			
OPC27994		O-RING FEMALE 90° ELBOW WITH LOW PRESSURE VALVE FOR R1234YF				-10 -11	-10 -12			

NOTE: Dash numbers in table indicate size of termination end or additional tail sizes

ACCESSORIES

CODE	VALVE TYPE		VALVE CORE	CAP
JC9000984		CHARGE VALVE - 1/4" SAE FOR R134A		
JC9000981		LOW PRESSURE CHARGE VALVE FOR R134A		
JC9000980		HIGH PRESSURE CHARGE VALVE FOR R134A		
JC9000983		LOW PRESSURE VALVE ADAPTER FOR R134A		
JC9000982		HIGH PRESSURE VALVE ADAPTER FOR R134A		
1003326		90° LOW PRESSURE VALVE ADAPTER FOR R134A		
1004323		90° HIGH PRESSURE VALVE ADAPTER FOR R134A		
			JC9001188	HP 9001186 LP 9001187 1/4 SAE CHARGE VALVE JC9001210

FITTINGS 30

CODE	VALVE TYPE	NOTES	VALVE CORE	CAP
1019327		90° LOW PRESSURE VALVE ADAPTER FOR R1234YF		
1019326		90° HIGH PRESSURE VALVE ADAPTER FOR R1234YF		
JC2014440		LOW PRESSURE CHARGE VALVE FOR R1234YF		
JC2014439		HIGH PRESSURE CHARGE VALVE FOR R1234YF		
			JC2014441 VALVE CORE FOR R1234YF	JC2014452 HP/LP VALVE CAP F OR R1234YF



ACCESSORIES

ELASTOMERIC INSULATING SLEEVE

PROTECTION TO AVOID CONDENSATION

CODE	DESCRIPTION	I.D.	WALL THICKNESS
9001126	ARMAFLEX D10X6	10.0	6.0
9001127	ARMAFLEX D12X6	12.0	6.0
9001129	ARMAFLEX D15X6	15.0	6.0
9001132	ARMAFLEX D18X6	18.0	6.0
2012628	ARMAFLEX D20X6	20.0	6.0
JP28B08022I099	ARMAFLEX D22X6	22.0	6.0
JP28B08029I099	ARMAFLEX D28X6	28.0	6.0
JP28B08028I099	ARMAFLEX D28X9	28.0	9.0
2007915	ARMAFLEX D30X9	30.0	9.0
JP28B08035I099	ARMAFLEX D35X9	35.0	9.0
JP28B08042I099	ARMAFLEX D42X9	42.0	9.0

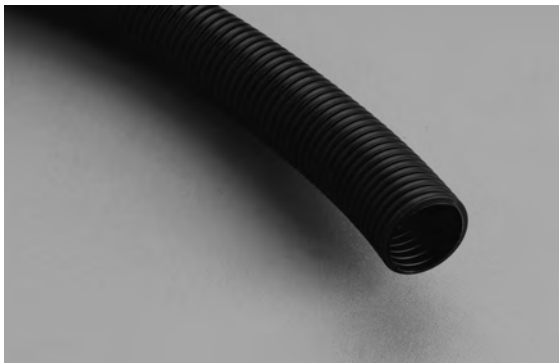

ACCESSORIES

CORRUGATED TUBE

ABRASION RESISTANCE

CODE	DESCRIPTION	I.D.	WALL THICKNESS
2009051	DN17 SLITTED	16.8	1.8
JP41B08019I099	DN19 SLITTED	19.4	2.0
JP41B08022I099	DN22 SLITTED	21.8	1.7
2009064	DN23 SLITTED	23.7	2.0

FURTHER DIMENSIONS AVAILABLE ON REQUEST



ACCESSORIES

SLEEVE FOR PROTECTION FROM RADIANT HEAT

PROTECTION AGAINST HEAT RADIATION SOURCES

CODE	DESCRIPTION	I.D.	WALL THICKNESS
JP27M08020I099	WEST-SR-D20	20.0	1.4
JP27M08024I099	WEST-SR-D24	24.5	1.4
JP27M08026I099	WEST-SR-D26	26.5	1.5
JP27M08028I099	WEST-SR-D28	28.0	1.5
JP27M08030I099	WEST-SR-D30	30.0	1.6
JP27M08032I099	WEST-SR-D32	32.0	1.6
2007154	WEST-SR-D34	34.0	1.6



ACCESSORIES

HTPS PROTECTION SPRING

HOSE ABRASION PROTECTION

CODE	DESCRIPTION	I.D.	WALL THICKNESS
JP12B03010I099	HT PROTECTION SPRING DN10	9.5	1.0
JP12B03013I099	HT PROTECTION SPRING DN13	12.7	1.8
JP12B03016I099	HT PROTECTION SPRING DN16	16.0	1.8
JP12B03019I099	HT PROTECTION SPRING DN19	19.0	2.3
JP12B03025I099	HT PROTECTION SPRING DN25	25.4	2.3



ACCESSORIES

TOOL FOR ASSEMBLING

CODE	DESCRIPTION		NOTES
JT600069	ASSEMBLY KIT LUGGAGE		THE LUGGAGE CONTAINS TOOLS FOR ASSEMBLING
JT9001398	CUTTING TOOL		FOR ASSEMBLING REFRIMASTER PLUS HOSE
JT2013199	PLIERS		FOR ASSEMBLING REFRIMASTER PLUS HOSE

Refrigeration applications are so many and varied that it would be pretty much impossible to develop industrialised products for every possible situation. However, at Manuli Hydraulics we are fully prepared to meet any application challenge that our OEM partners can present us with, which is why we offer our Bespoke Solutions Program (BSP).

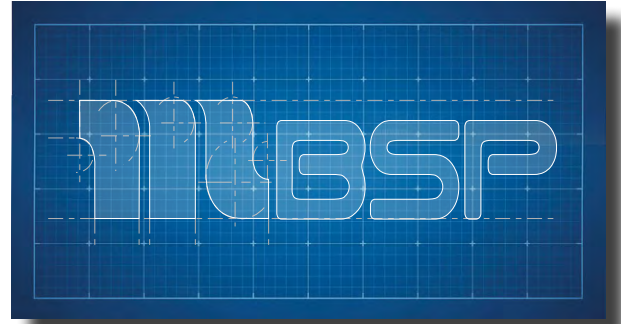

The BSP is just one way that Manuli Hydraulics provides an added value service to our OEM partners. Manuli Hydraulics is structured in such a way that we can tailor solutions to the specific requirements of our customers in a way that our competitors never could. We are small enough to be agile and responsive, yet large enough to have the design and manufacturing capabilities to produce bespoke products at a reasonable price. Used by some of the largest and most respected OEMs around the world, the Manuli Bespoke Solutions Program means that you never have to compromise on your refrigeration system design again.

WHAT DO WE OFFER?

Manuli Hydraulics can provide a full service solution from design to manufacture for bespoke steel, bent-tube refrigeration fittings. These can include valves and other speciality features as necessary. We are also happy to receive designs from customers which we will then analyse and, through collaboration with the customer, determine the optimal solution for the given application.

Bespoke fittings are typically divided into two categories

- Single-bend and straight-tube fitting
- Manipulated tube (multiple bend) fitting

Both categories are available either as they are or with a selection of accessories and additional components.

Bespoke fittings are typically requested in sizes DN 10 to DN 18, although we have the capability to bend fittings from DN 6 to DN 32



WHAT IS THE PROCESS TO ORDER BESPOKE COMPONENTS?

The process to order bespoke fittings is as follows

1. Request for quotation from customer

There are several ways in which quotations can be requested:

- Simple parts can be requested using the Manuli Refrigeration Fittings Part Numbering System (see *page ##*) to build up a part number
- Technical drawings or 3D CAD files can be provided by the customer
- Samples of required fitting (eg: hand-bent prototypes / test fittings) can be supplied for us to measure on our advanced production equipment

2. Quotation and preliminary drawings supplied to customer

We will provide the customer with a cost breakdown, including minimum order quantities, based on the design requested in the initial stage.

We will also always provide a drawing of the proposed fitting for customer approval. This drawing will indicate any modification that we have suggested in order to make the final part easier or cheaper to produce.

3. Approval from customer and prototype order

Once the customer is happy with the quotation and design we will usually be required to produce a prototype for the customer to check and approve. Prototyping is a one-off cost which allows customers to check the actual product that they plan to order ahead of ordering a production volume. This allows any issues to be identified prior to batch production

4. Ordering of production volumes

Once the customer is satisfied with the prototype the next step is to produce production amounts. The typical minimum order quantity is 25 pieces, although certain special cases may require a minimum order quantity larger than this.

WHAT IS THE TYPICAL LEAD-TIME FOR BESPOKE ITEMS?

This is a tricky question as every bespoke project is, by its very nature, unique, so there is not really any “standard” lead-time for the process. However, we would advise a minimum allowance of 6 weeks for the quotation, design, prototype approval and production steps, although the complexity of the product would potentially have a measurable effect on the overall lead-time. We will of course work with customers to streamline the process as much as possible.

PLEASE CONTACT OUR TECHNICAL TEAM FOR MORE INFORMATION ON BESPOKE FITTING SOLUTIONS

TWO-PIECE REFRI FITTINGS

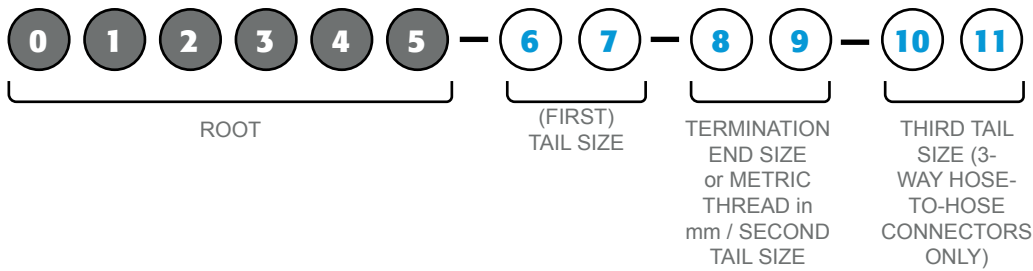

DIGIT "0"

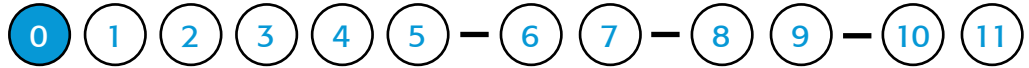

Value **Description**

C Always

DIGITS "1"



Value **Description**

- 1** Male or "Hose to hose" Connectors type Star-Crimp
- 2** Female or Flange type Star-Crimp
- 3** Male or "Hose to hose" Connectors type Frigolic
- 4** Female or Flange type Frigolic

DIGITS "2-3"



The **numbers** stated in these positions refer to the termination end or to the second tail. For the coding, see table "Termination Ends Type".

DIGIT "4"



Value **Description**

- 1** Straight
- 4** 45° Swept
- 8** Compact type
- 9** 90° Swept
- H** 3-ways connector with "h" configuratio
- T** 3-ways connector with "T" configuratio
- Y** 3-ways connector with "Y" configuratio

TWO PIECES REFRI FITTINGS (CONTINUED)

DIGITS "5"



Value	Description
0	No charge valve
2	1/4" SAE charge valve (thread 7/16"-20-UNF)
3	R-1234yf High Pressure charge valve
4	R-1234yf Low Pressure charge valve
5	R-134a High Pressure charge valve
6	R-134a Low Pressure charge valve

DIGIT "6-7"



Tail size

DIGIT "8-9"



These digits specify the termination end size or the second tail size

DIGIT "10-11"



These digits specify the third tail size (only for 3-ways hose to hose connectors)

FITTINGS 36

RULES FOR THE SIZE INDICATION IN THE HOSE TO HOSE CONNECTORS

In the double connectors, when the tails are part of the same family, the first size is the smallest. If the tails have the same size, this is repeated two times.

In the 3-ways connectors, tails in position "1" and "2" must be part of the same family. All the sizes are indicated following this order:

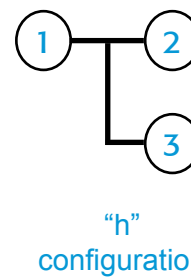
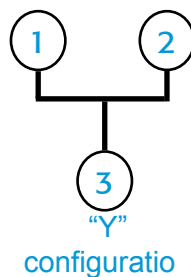
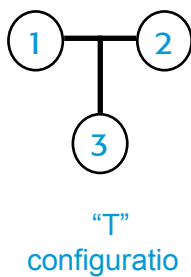

ONE-PIECE REFRI FITTINGS

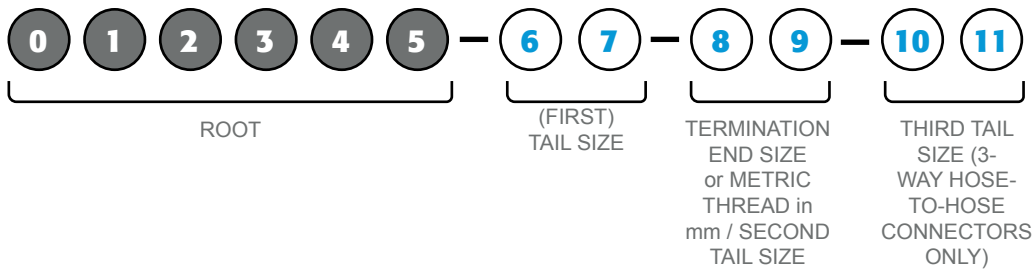

DIGIT "0"



Value **Description**

OPC Always

DIGIT "1"



Value **Description**

- 1 Male or Double connector type Fast-Crimp (deformation)
- 2 Female or Flange type Fast-Crimp (deformation)
- 3 Male or Double connector type Fast-Crimp (brazed)
- 4 Female or Flange type Fast-Crimp (brazed)

DIGITS "2-3"



The numbers in these positions specify the termination end or the second tail.

See "Termination Ends Type" table for coding details.

DIGIT "4"



Value **Description**

- 1 Straight
- 4 45° Swept
- 8 Compact type
- 9 90° Swept
- H 3-ways connector with "h" configuratio
- T 3-ways connector with "T" configuratio
- Y 3-ways connector with "Y" configuratio

ONE-PIECE REFRI FITTINGS (CONTINUED)

DIGITS "5" 0 1 2 3 4 5 — 6 7 — 8 9 — 10 11

Value	Description
0	No charge valve
2	1/4" SAE charge valve (thread 7/16"-20-UNF)
3	R-1234yf High Pressure charge valve
4	R-1234yf Low Pressure charge valve
5	R-134a High Pressure charge valve
6	R-134a Low Pressure charge valve

DIGIT "6-7" 0 1 2 3 4 5 — 6 7 — 8 9 — 10 11

Tail size

DIGIT "8-9" 0 1 2 3 4 5 — 6 7 — 8 9 — 10 11

These digits specify the termination end size or the second tail size

DIGIT "10-11" 0 1 2 3 4 5 — 6 7 — 8 9 — 10 11

These digits specify the third tail size (only for 3-ways hose to hose connectors)

RULES FOR THE SIZE INDICATION IN THE HOSE TO HOSE CONNECTORS

In the double connectors, when the tails are part of the same family, the first size is the smallest. If the tails have the same size, this is repeated two times.

In the 3-ways connectors, tails in position "1" and "2" must be part of the same family. All the sizes are indicated following this order:

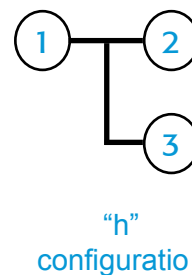
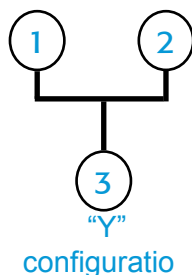
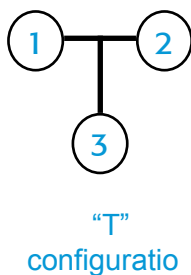

REUSABLE REFRI FITTINGS

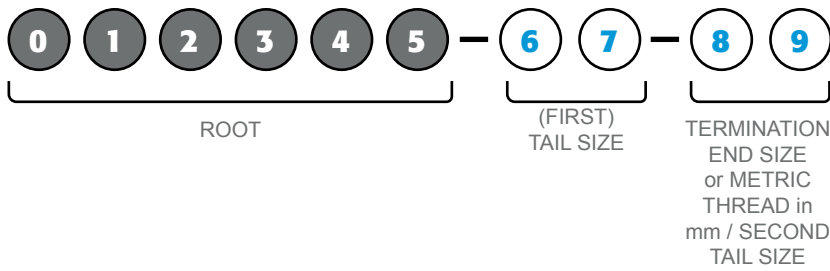

DIGIT "0"



Value

K

Description

Always

DIGIT "1"



Value

3

Description

Male or Double connector type Star-Fit

4

Female or Flange type Star-Fit

DIGITS "2-3"



The numbers in these positions specify the termination end or the second tail.

See "Termination Ends Type" table for coding details.

DIGIT "4"



Value

1

Bending Angle

Straight

4

45° Swept

8

Compact type

9

90° Swept

REUSABLE REFRI FITTINGS (CONTINUED)



These digits specify first tail size



These digits specify the termination end size or the second tail size

RULES FOR THE SIZE INDICATION IN THE HOSE TO HOSE CONNECTORS

In the double connectors, when the tails are part of the same family, the first size is the smallest. If the tails have the same size, this is repeated two times.

CONNECTORS SUPPLIED WITH FERRULE OR CLAMP



CONNECTORS SUPPLIED WITH FERRULE

For connectors supplied with ferrule, the second dash is replaced by a letter according to the following specifications

Value	Description
B	Ferrule type K00400

TERMINATION END TYPES

DIGIT	REFRI	DESCRIPTION (MALE END)	DESCRIPTION (FEMALE END)
00	00	DOUBLE CONNECTOR (SAME TAIL IN TWO-ENDS CONNECTORS) / NO END (PLUG)	NO END (PLUG)
11	11	METRIC MALE 24° CONE SEAT LIGHT TYPE DIN 3861 / ISO 8434-1	-
15	15	-	METRIC FEMALE 24° CONE O-RING LIGHT TYPE DIN 3865 / ISO 8434-1
24	24	ORFS MALE ISO 8434-3 / SAE J1453	ORFS FEMALE ISO 8434-3 / SAE J1453
25	25	JIC MALE (37° CONE) ISO 8434-2 / SAE J514	JIC FEMALE (37° CONE SEAT) ISO 8434-2 / SAE J514
26	26	SAE MALE (45° CONE) SAE J512	SAE FEMALE (45° CONE SEAT) SAE J512
37	37	METRIC MALE 60° CONE SUPERLIGHT DIN 3863 BULKHEAD	FLANGE ISO/SAE 62 PLUS / FLANGE (A/C)
76	76	ISO 6164 FLANGE TYPE 40 MPA WITHOUT O-RING GROOVE / EXPANSION VALVE SHORT PILOT (A/C)	ISO 6164 FLANGE TYPE 40 MPA WITH O-RING GROOVE / EXPANSION VALVE (A/C)
79	79	FIXED MALE O-RING SEAT (A/C)	HUB API 16A (TYPE 16BX) / FEMALE O-RING (A/C)
80	80	MALE SWIVEL O-RING (A/C)	FLANGE API 6A (TYPE 6B/6BX) / O-RING SHORT PILOT (A/C)





AUTOTECH MINING

AUTO TECH MINING
AUTHORISED MANULI AIR CONDITIONING AUSTRALIA

- SUPPLY MINING AIR CONDITIONING SERVICE KIT, HOSE KIT & SPARE PARTS
- AUTHORISED SIGMA PART SUPPLIER
- LIEBHERR, CATERPILLAR, TEREX, HITACHI
- EPI ROC, SANDVIK, SK, D65 & PIT VIPER

FOR PART ENQUIRY PLEASE CONTACT:

info@autotechmining.com.au
www.autotechmining.com.au
0412 228 671

LEGEND OF SYMBOLS



Outside Diameter (O.D.)



Reinforcement Outside Diameter (R.O.D.)



Minimum Bend Radius



Insert



Maximum Working Pressure



Weight



Burst Pressure: The minimum guaranteed burst pressure of the hose;
Equivalent or superior to the minimum requirements of the reference specifications

GLOSSARY OF TERMS

Continuous service: Refers to the working temperature range

Recommended fluids: Fluid types that the hose can convey with excellent / good chemical compatibility.

HOSE SIZE CONVERSION CHART

REFRIGERATION			
HOSE SIZE			
DN	dash	inch	SAE
5	-04	3/16"	1/4"
8	-06	5/16"	3/8"
10	-08	13/32"	1/2"
12 (13)	-10	1/2"	5/8"
16	- 12	5/8"	3/4"
22	-16	7/8"	1"
28	-20	1.1/8"	1.1/4"
35	-24	1.3/8"	1.1/2"

ASSEMBLY INSTRUCTIONS

Refrimaster Plus Mounting Kit



REFRI 

- A** Manual cutter
- B** “CLICK” close pliers

PN# JT600069



Mobile Manual Hydraulic Crimper with dies
PN# MHP80

Add On Option: Air operated Pedal Kit
PN# MHP80PPPM

REFRIMASTER PLUS WITH CLAMP



- 1** Check the dimensions of the components



- 2** Cut the end of the hose using the manual cutter

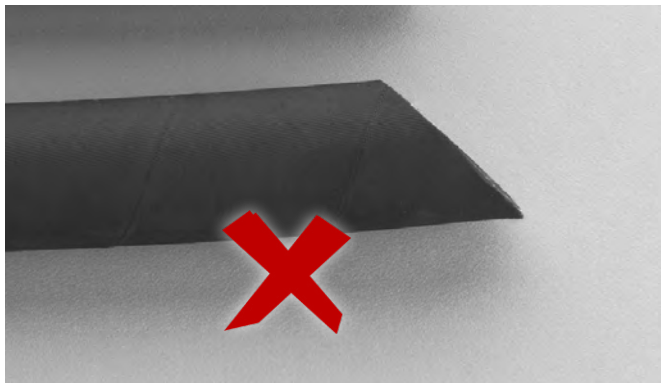

- 3** The end of the hose should be cut squarely to $\pm 2^\circ$



- 4** Place the double clamp on the hose so that the tooth on the bar (A) comes into contact with the end of the hose that has been cut



- 5** Grease the end of the fitting with the same oil used in the air conditioning system

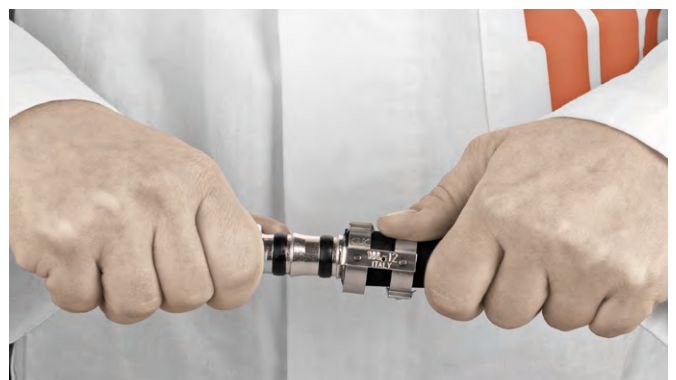

- 6** Fully insert the fitting into the hose and rotate the fitting to be in the correct orientation



7 Use the 'CLICK' closing pliers to close the clamps as follows



8 **NOTE:** Due to the size of the DN22 clamp it is necessary to compress it slightly by hand so that the pliers can fit over the clamping hooks



9 Use the pliers to compress the double clamp until it clicks closed



10 Done



11 Ensure the two clamps are approximately parallel to each other



12 If the clamps are not parallel, remove the clamp and start again with a new clamp.



WARNING: Do not reuse the clamp

SOLUTION WITH BRAZED INSERT

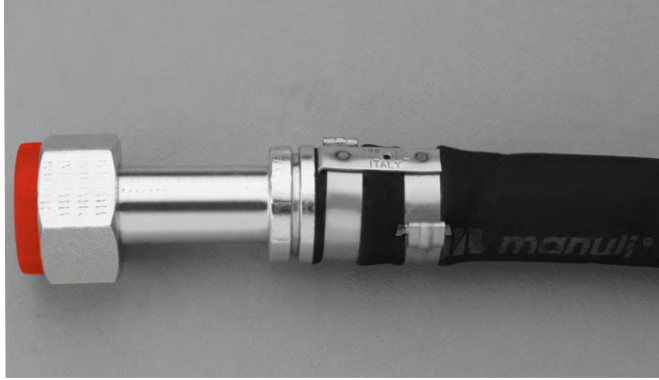

13a RIGHT

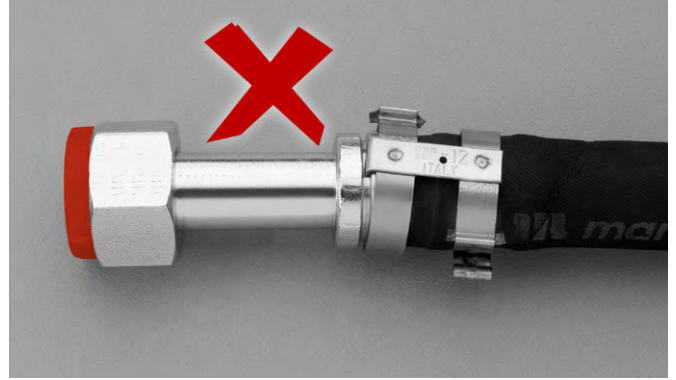

14a WRONG



WARNING: Position the clamp correctly

SOLUTION WITH FORMED INSERT



13b RIGHT

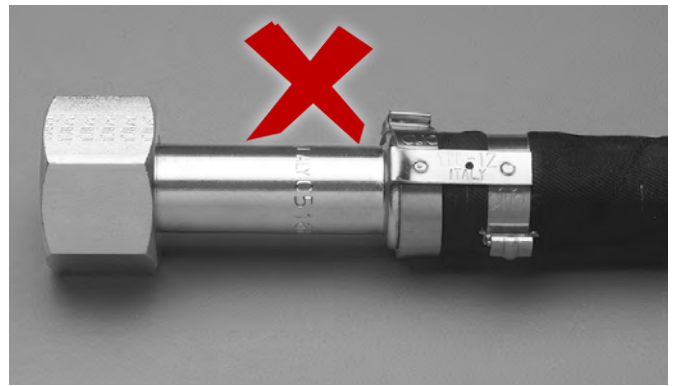

14b WRONG



WARNING: Position the clamp correctly

REFRIMASTER PLUS WITH FERRULE



1 Check the dimensions of the components



2 Cut the end of the hose using the manual cutter

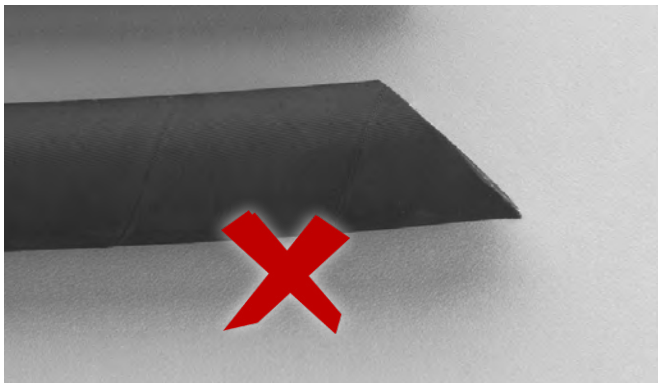

3 The end of the hose should be cut squarely to $\pm 2^\circ$

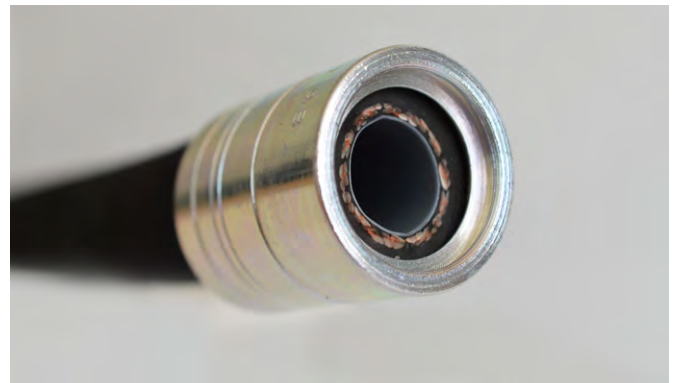

4 Place the ferrule on the hose so that the internal stop comes into contact with the end of the hose that has been cut



5 Grease the end of the fitting with the same oil used in the air conditioning system

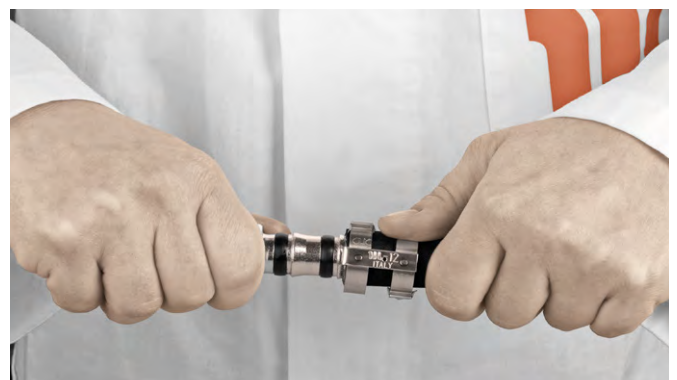

6 Fully insert the fitting into the hose and rotate the fitting to be in the correct orientation



7 Set up the crimping machine using the die set which is most appropriate for the crimping diameter required (see latest version of Crimping Data)



8 Ensure that the full length of the ferrule is covered by the dies

SOLUTION WITH BRAZED INSERT



9a Pay attention to how the fitting is inserted into the ferrule

SOLUTION WITH FORMED INSERT



9b Pay attention to how the fitting is inserted into the ferrule



10 Inspect the crimped dimension using a calibrated vernier. Check the diameter at the centre of the ferrule against the relevant value in the latest version of the crimping data

ULTRASTAR WITH REUSABLE FITTINGS

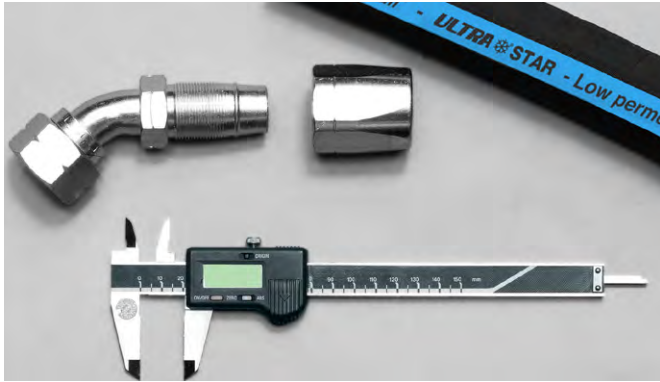

1 Check the dimensions of the components



2 Cut the hose by using a sharpened cutting disc - do not use an abrasive disc. Avoid causing damage to the wire braid during cutting. Clean the hose carefully from cutting residue.



3 The end of the hose should be cut squarely to $\pm 2^\circ$ and there should be no ragged edges



4 Secure the socket vertically in a bench-vice and screw in the hose, turning counter-clockwise, until it reaches the bottom of the socket. Unscrew the hose by $\frac{1}{4}$ turn to prevent damage in later steps.



5 Use an indelible pen to mark the relative positions of the socket and the hose. This will make it easy to check that no unwanted rotation of the socket on the hose has occurred.



6 Secure the hose and socket vertically in the bench-vice. Using a suitable oil, generously lubricate the thread and taper of the fitting as well as the inside of the hose and socket.



- 7** Insert the fitting into the hose and, while pressing down slightly, tighten it with a wrench by turning clockwise. Turn the fitting with a smooth, continuous motion to prevent damage to the hose.



- 8** Once the hexagon of the fitting has contacted the socket, back off the fitting in order to align it correctly. The maximum permissible gap between the hexagon and the socket shoulder is 3mm

ULTRASTAR WITH CRIMPED FITTINGS



1 Check the dimensions of the components



2 Cut the hose by using a sharpened cutting disc - do not use an abrasive disc. Avoid causing damage to the wire braid during cutting. Clean the hose carefully from cutting residue.



3 The end of the hose should be cut squarely to $\pm 2^\circ$ and there should be no ragged edges

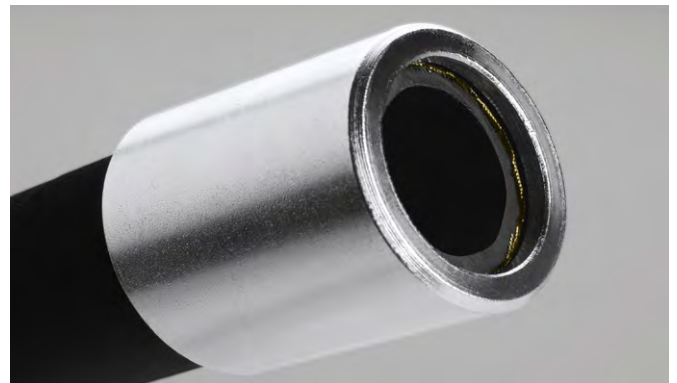

4 Place the ferrule on the hose so that the internal stop comes into contact with the end of the hose that has been cut



5 Grease the end of the fitting with the same oil used in the air conditioning system



6 Fully insert the fitting into the hose and rotate the fitting to be in the correct orientation



- 7** Set up the crimping machine using the die set which is most appropriate for the crimping diameter required (see latest version of Crimping Data)



- 8** Ensure that the full length of the ferrule is covered by the dies



- 9** Inspect the crimped dimension using a calibrated vernier. Check the diameter at the centre of the ferrule against the relevant value in the latest version of the crimping data

MHP 80
PN# MHP80



KEY FEATURES

- Compact
- Lightweight
- Easy to use
- Balanced design
- Dual stage pump
- 1" Die Set included

OPTIONAL



Maintenance Kits

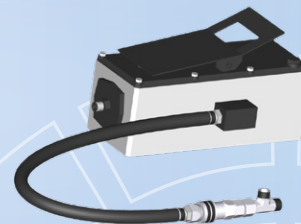

Hydro-pneumatic Pump

PN# MHP80PPPM

TECHNICAL SPECIFICATIONS

CRIMP RANGE

4 - 43 mm (0.157 - 1.693")

CRIMP FORCE

80 t

OPENING WITH DIES

+20 mm (+0.787")

COMPLETE OPENING

59 mm (2.323")

MASTER DIE LENGTH

56 mm (2.205")

STANDARD DIES

15, 18, 21, 24, 27, 30, 39

DIMENSIONS

330 x 250 x 400 mm
(13 x 10 x 16")

PACKAGING

800 x 600 x 830 mm
(31 x 24 x 33")

NET WEIGHT

28 kg (62 lb)

GROSS WEIGHT

41 kg (90 lb)

TECHNICAL FEATURES

Hand pump: 5000 psi
(double speed)

HOSE AND FITTINGS SELECTION

HOSE TYPE	FITTING TYPE	MAX HOSE SIZE
2 WIRE BRAID & TEXTILE	MF2000 MULTIFIT; MF3000 OPK; MF3000 OPF	1"
3 WIRE (1 BRAID + 2 SPIRAL)	MF2000 MULTIFIT	½"
4 WIRE SPIRALS	MF2000 MULTIFIT; MF3000 OPK	½"

M 22 CUT / MV 22 CUT

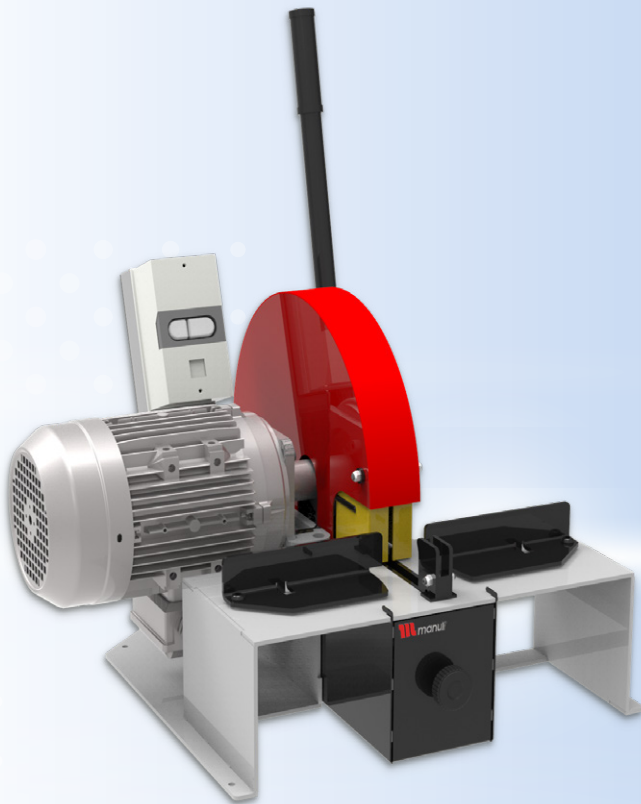

KEY FEATURES

- Smooth bending system
- 90° cut
- Clean cut
- Scalloped blade
- Dust collector included
- Multiple voltage options

TECHNICAL SPECIFICATIONS

CAPACITY	DIMENSIONS
2wb: 1¼" max.	630 x 485 x 650 mm
4ws: 1¼" max.	(25 x 19 x 26 ")
ROTATION SPEED	PACKAGING
3000 rpm	800 x 600 x 830 mm
SCALLOPED BLADE DIAMETER	(31 x 24 x 33")
254 mm (10") included	NET WEIGHT
MAX HOSE OD.	42 kg (93 lb)
50 mm (1.969")	GROSS WEIGHT
MOTOR	55 kg (121 lb)
2.2 kW	TECHNICAL FEATURES
VOLTAGES	Dimensions van type machine:
220/240 V, 3Ph, 50 Hz	488 x 630 x 650 mm
380/415 V, 3Ph, 50 Hz	(19.2 x 24.8 x 25.6");
208/240 V, 3Ph, 60 Hz	38 kg (84 lb)
380/415 V, 3Ph, 60 Hz	
12/24 V also available upon request	

STANDARD



Scalloped Blade

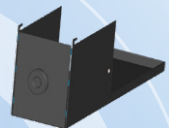

Dust Collector

OPTIONAL



Battery & Charger

MB 137 EVO

PN# MB137

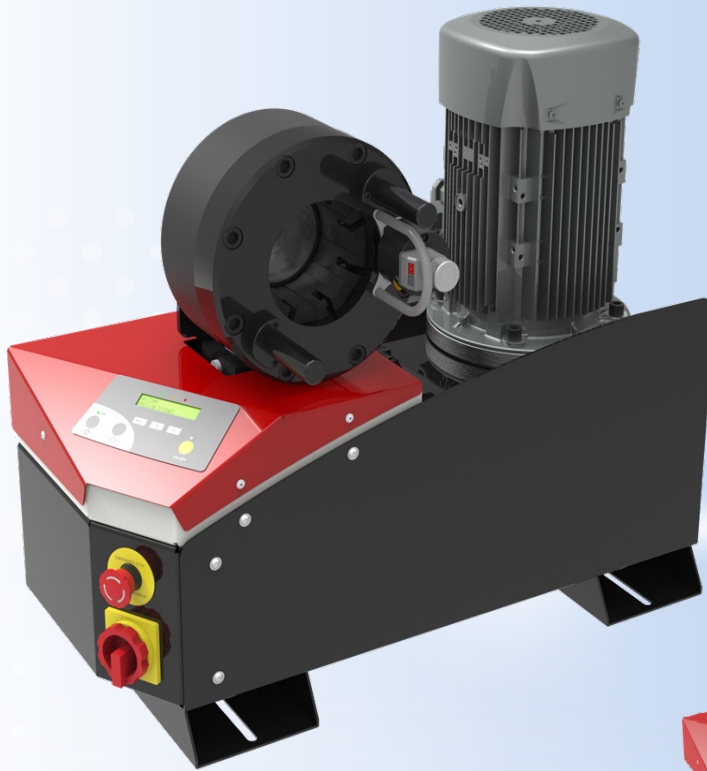

KEY FEATURES

- Crimp force of up to 137 tonnes for hoses up to 1 1/4"
- Easy to use and robust
- Extensive range of dies to suit crimping of hydraulic hoses
- Easy to set up and maintain
- Fast and reliable
- Numerical micrometer
- Model shown equipped with SC control panel
- Calliper option on SCE control panel
- Bluetooth as standard on SC and SCE control panels



CONTROL OPTIONS AVAILABLE ON REQUEST

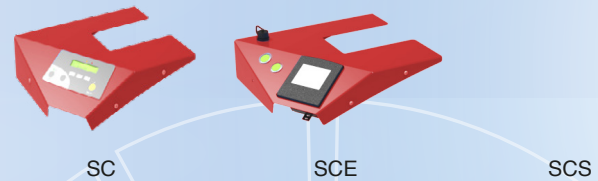

TECHNICAL SPECIFICATIONS

CRIMP RANGE	NOISE LEVEL
4 - 70 mm (0.157 - 2.756")	70 dB A
CRIMP FORCE	MOTOR
137 t	4.0 kW
OPENING WITH DIES	VOLTAGES
+28 mm (+1.102")	220/240 V, 3Ph, 50 Hz
COMPLETE OPENING	380/415 V, 3Ph, 50 Hz
100 mm (3.937")	208/240 V, 3Ph, 60 Hz
MASTER DIE LENGTH	380/415 V, 3Ph, 60 Hz
75 mm (2.953")	Other voltages available on request
STANDARD DIES	DIMENSIONS
15, 18, 21, 24, 27, 30, 33, 36, 39, 42, 45, 48, 51	765 x 400 x 650 mm
	(30 x 16 x 26")
	NET WEIGHT
	160 kg (353 lb)

OPTIONAL







MINING & CIVIL

AUTO AIR CONDITIONING SPECIALISTS

GOLDFIELDS - PILBARA

CATERPILLAR
HITACHI
Inspire the Next

TEREX
KOMATSU

LIEBHERR
Epiroc

SIGMA
SANDVIK



WE STRIVE TO REDUCE COSTLY UNSCHEDULED MACHINE DOWNTIME

- ▶ Supply & Install Mid-life service kits for Diggers & Drills.
- ▶ Rebuilding of Evaporators & Condensers at Perth workshop.
- ▶ Improve liability & Availability of machines.



- ▶ Supply SIGMA & OEM air conditioning parts.
- ▶ Supply SIGMA Service Kits & Hose Kits.
- ▶ Competitive Pricing.

Preventative maintenance planning.

- Pre Inspection
- Scope
- Parts
- Labour

ARC
REGISTERED
LICENSE AU 41694

To find out more, contact:

04 12 228 671
08 61 18 4152

info@autotechnining.com.au
www.autotechnining.com.au